

PN16 Cast Iron Globe Valve

Features

- Flange Mounting PN16 Only
- BS EN558-1 Series 10
- Conforms to BS5152



Pressure / Temperature

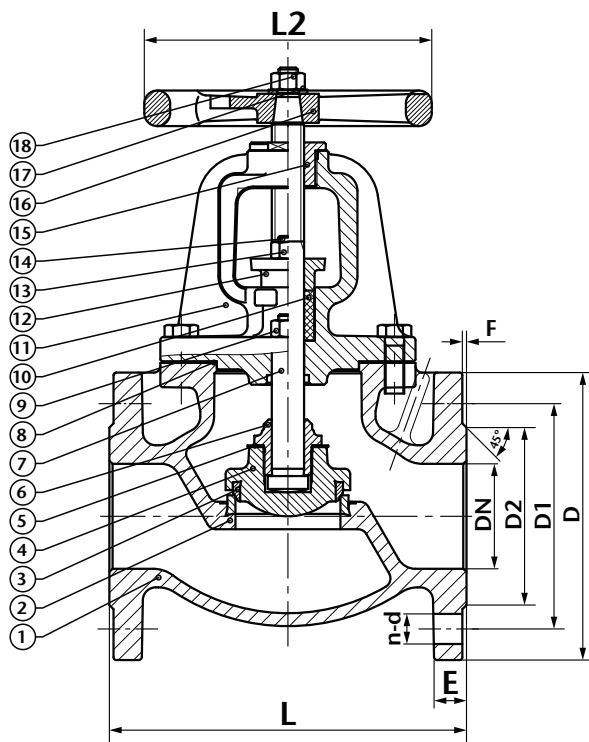
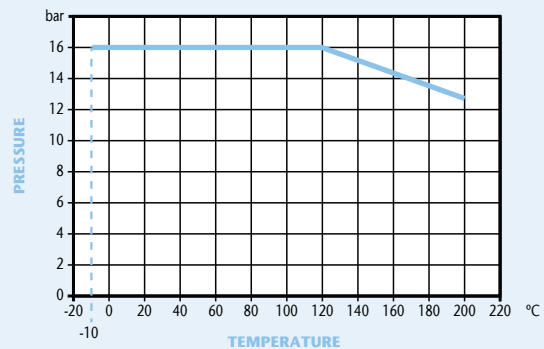

DN	50	65	80	100	125	150	200	250	300
D	165	185	200	220	250	285	340	405	460
D1	125	145	160	180	210	240	295	355	410
D2	99	118	132	156	184	211	266	319	370
E	20	17.5	19.1	23.9	23.9	25.4	28.6	30.2	31.8
F	3	3	3	3	3	3	3	3	4
L	203	216	241	292	330	356	495	622	698
L2	178	178	200	254	300	300	348	400	457
n-d	4-19	4-19	8-19	8-19	8-19	8-23	12-23	12-28	12-28

N.	Part Name	Materials
1	Body	Cast Iron
2	Body Ring	Cast Bronze
3	Disc Ring	Cast Bronze
4	Disc	Cast Iron
5	Stop Washer	Stainless Steel 304
6	Nut	Cast Brass
7	Stem	Brass
8	Flange Gasket	Graphite
9	Bolt	Cast Iron
10	Packing	Graphite
11	Bonnet	Cast Iron
12	Gland	Ductile Iron
13	Nut	Steel
14	Bolt	Steel
15	Stem Nut	Cast Brass
16	Handwheel	Cast Iron
17	Washer	Steel
18	Nut	Steel

Technical Data

Max Pressure	16 Bar
Working Temperature	-10°C to +200°C

Dimensions in mm

This data sheet is designed as a guide and should not be regarded as wholly accurate in every detail. We reserve the right to amend the specification of any product without notice.